

KEYNOTES

DESCRIPTION

1. PROPOSED VEGETATIVE MOUND
2. PARKING LOT TREES
3. PROPOSED ACCENT SCREEN TREES
4. PROPOSED PATIO
5. PROPOSED STEEL SHADE ARBOR
6. DENOTES LANDSCAPED AREA
7. EXISTING LANDSCAPE TO REMAIN
8. EXISTING ENTRY MONUMENT SIGNAGE TO REMAIN
9. EXISTING OAKS TO REMAIN
10. PROPOSED TRASH ENCLOSURE
11. EXISTING OAKS TO BE REMOVED
12. PROPOSED SCREEN WALL WITH EVERGREEN TREES
13. PROPOSED MONUMENT SIGNAGE-SEE CIVIL PLANS
14. PROPOSED NATIVE BENTGRASS
15. PROPOSED DOUBLE RAIL CONCRETE FENCE

PRELIMINARY TREE LIST AND LEGEND

SYMBOL	BOTANICAL NAME COMMON NAME	SIZE WHY SIZE	WATER USE	DESIGN USE
	ACER RUBRUM ARMSTRONG ARMSTRONG COLUMNAR MAPLE	15 GAL 15'X40'	MOD	STREET TREE
	CEDRUS DEODORA DEODAR CEDAR	15 GAL 35'X65'	LOW	SCREEN TREE
	LAGERSTROEMIA INDICA 'ARAPAH0' GRAPE MYRTLE	15 GAL 15'X20'	LOW	ACCENT TREE
	LAURUS NOBILIS GRECIAN LAUREL	15 GAL 20'X20'	MOD	SCREEN TREE
	MAGNOLIA GRANDIFLORA LITTLE GEM LITTLE GEM MAGNOLIA	24" BOX 15'X20'	LOW	ACCENT TREE
	NYSSA SYLVATICA SOUR GUM	24 BOX 25'X45'	LOW	STREET TREE
	OLEA EUROPAEA 'MAJESTIC BEAUTY' FRUITLESS OLIVE	15 G/VARIES	LOW	ACCENT TREE
	PISTACIA CHINENSIS CHINESE PISTACHE	24" BOX 40'X40'	MOD	SHADE TREE
	TILIA CORDATA GREENSPIRE LITTLE LEAF LINDEN	15 GAL 30' X 40'	MOD	SCREEN TREE
	QUERCUS WISLIZENII INTERIOR LIVE OAK	24" BOX NAT. 50'X60'	LOW	STREET TREE
	ULMUS PARVIFOLIA 'TRUE GREEN' EVERGREEN ELM	24" BOX 30'X35'	MOD	SHADE TREE

NOTE: 33% OF TOTAL TREE QUANTITY SHALL BE 24" BOX.

SHRUBS: BACKGROUND/SCREEN

SYMBOL	BOTANICAL NAME COMMON NAME	SIZE	WATER USE
	BACKGROUND / SCREEN SHRUBS - EVERGREEN, LARGE SHRUBS TO 6'-0" USED FOR REDUCING BUILDING MASS OR SCREENING UNDESIRABLE VIEWS.		
	ELAEAGNUS X EBBINGEI GILT EDGE GILT EDGE SILVERBERRY	5 G	LOW
	ARCTOSTAPHYLOS HOWARD MCMINN HOWARD MCMINN MANZANITA	5 G	LOW
	ROSMARINUS TUSCAN BLUE TUSCAN BLUE ROSEMARY	5 G	LOW
	HYPERICUM X MOSERIANUM GOLD FLOWER	5 G	MOD
	PODOCARPUS MACROPHYLLUS 'MAKI' SHRUBBY YEW PINE	5 G	MOD
	PRUNUS C. BRIGHT N TIGHT CAROLINA CHERRY	15 G	MOD
	RHAMNUS CALIFORNICA MOUND SAN BRUNO SAN BRUNO COFFEEBERRY	5 G	LOW
	XYLOSMA C. 'COMPACTA' COMPACT XYLOSMA	15 G	LOW

SHRUBS: FACER/FILLER

SYMBOL	BOTANICAL NAME COMMON NAME	SIZE	WATER USE
	FACER/FILLER SHRUBS & GRASSES EVERGREEN OR DECIDUOUS SHRUBS TO 4'-0". USED FOR "TERRACING" OF PLANT MATERIAL. SEASONAL COLOR AND SOFTENING OF BUILDING EDGES AND FOUNDATION SHRUBS.		
	AGAVE WEBERI WEBERS AGAVE	5 G	LOW
	CALLISTEMON V. 'LITTLE JOHN' DWARF BOTTLEBRUSH	5 G	LOW
	DIETES BICOLOR FORTNIGHT LILY	5 G	LOW
	LEPTOSPERMUM SCOPARIUM RUBY GLOW RUBY GLOW TEA TREE	5 G	LOW
	EUONYMUS JAPONICA GREENSPIRE GREENSPIRE EUONYMUS	5 G	LOW
	GREVILLEA CANBERRA HUMMINGBIRD BUSH	5 G	LOW
	PINUS MUGO MUGO MUGO MUGO PINE	5 G	LOW
	WESTRINGIA FRUTICOSA COAST ROSEMARY	5 G	LOW
	RHAPHOLEPIS UMBELLATA SOUTHERN MOON YEDDO	5 G	LOW

SHRUBS AND GROUNDCOVERS

SYMBOL	BOTANICAL NAME COMMON NAME	SIZE	WATER USE
	PERENNIALS, GRASSES, AND GROUND COVER MATERIAL - SMALL SCALE DUE TO PROJECT TYPE, EVERGREEN OR PERENNIAL SHRUBS TO 24" HIGH, USED AS A FILLER BETWEEN SITE WORK EDGES AND FACER SHRUBS.		
	ARCTOSTAPHYLOS U. URSI MANZANITA	1 G	LOW
	BOUTELOUA GRACILIS 'BLONDE AMBITION' BLUE GRAMA GRASS	1 G	LOW
	CISTUS 'SUNSET' MAGENTA ROCKROSE	1 G	LOW
	COPROSMA KIRKII COPROSMA	1 G	LOW
	HYPERICUM CALYCIUM AARONS BEARD	1 G	MOD
	LANTANA MONTEVEDENSIS LANTANA	5 G	LOW
	MUHLENBERGIA CAPILLARIS REGAL MIST PINK MUHLY	1 G	LOW
	MYOPORUM PARVIFOLIUM CREEPING MYOPORUM	1 G	LOW
	ROSA FLOWER CARPET (WHITE AND RED) FLOWER CARPET ROSE	1 G	MOD
	TRACHELOSPERMUM JASMINODES STAR JASMINE	1 G	MOD
	NATIVE BENTGRASS "NO MOW" OR "MOW FREE" NATIVE FESCUE BLEND	SOD	MOD
	BIOREMEDIATION AREA AND OR WATER QUALITY BASIN		
	JUNCUS EFFUSUS RUSH	1 G	MOD
	CORNUS STOLONIFERA 'KELSEY' DWARF REDTIG DOGWOOD	1 G	MOD
	LOMANDRA LONGIFOLIA BREEZE DWARF MAT RUSH	1 G	LOW

THE PLAZA AT BLUE OAKS PRELIMINARY LANDSCAPE PLAN

Roseville, CA

SCALE: 1" = 40'

SHEET
PL1

FUHRMAN LEAMY LAND GROUP
DESIGN · SERVICE · SOLUTIONS
2140 PROFESSIONAL DRIVE, SUITE 115 ROSEVILLE, CA 95661

DATE: 03/16/2020
PROJECT: TSD.16079

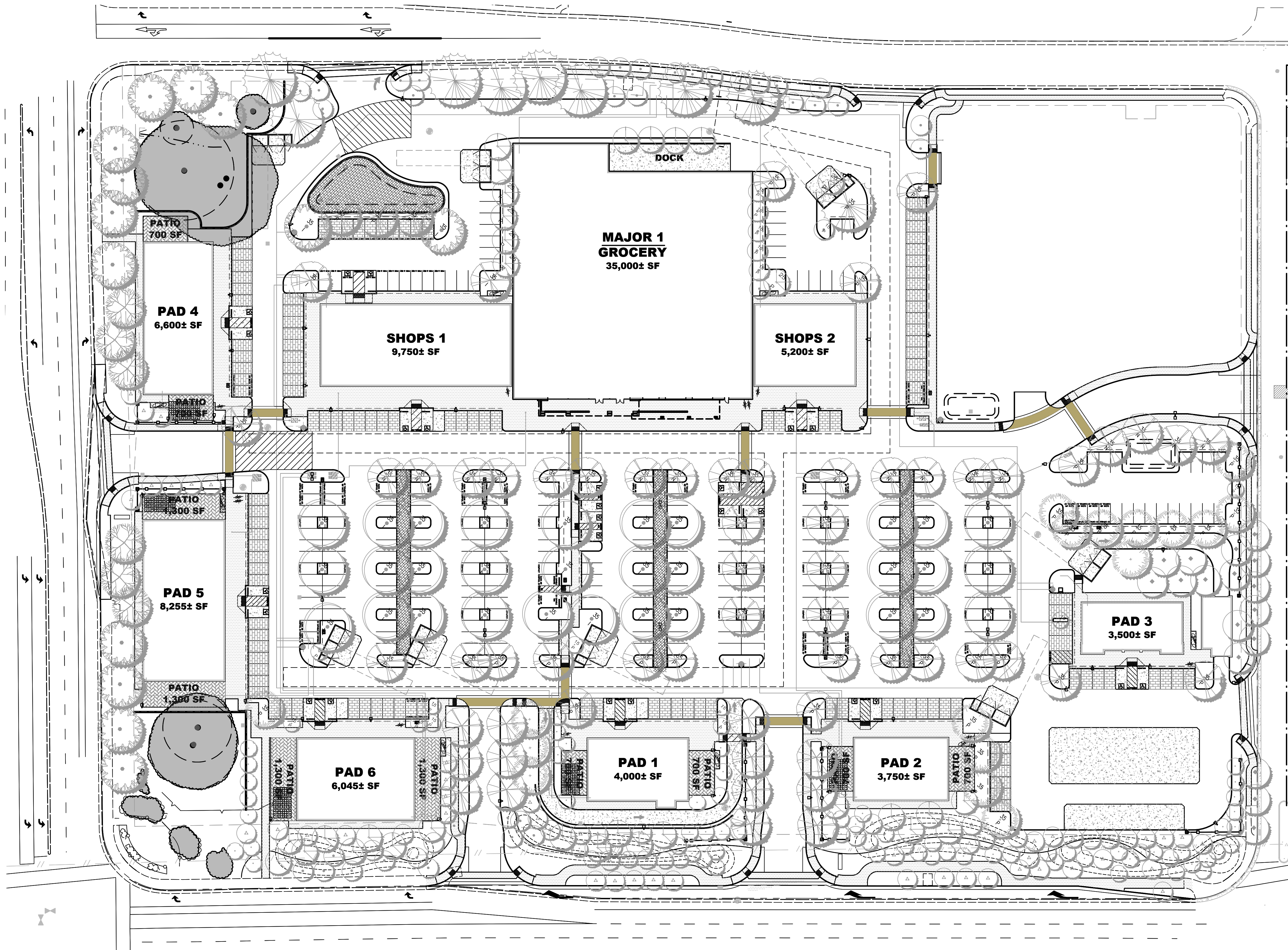

SHADE STUDY CALCULATIONS

PROJECT: THE PLAZA AT BLUE OAKS 12.4.2019

OVERALL SITE	QTY.	SQ. FT. AREA
STANDARD STALLS	352	95,040
COMPACT STALLS	34	8,568
HANDICAP STALLS	25	6,300
TOTAL PAVED PARKING AREA:		109,908
TOTAL SHADE REQUIRED:	50%	54,954
TOTAL SHADE PROVIDED:		64,731
TOTAL SHADE PERCENTAGE		58.9%

SYMBOL	PATTERN	QTY.	UNIT	IN S.F.	TOTAL S.F.
30 TO 35' TREES					
Ulmus p., Quercus w., Cedrus d.	35-I	41	X	961	39,401
	35-P	37	X	481	17,797
	35-N	19	X	240	4,560
25' TO 30' TREES					
Nyssa s.	30-I	0	X	707	0
	30-P	0	X	354	0
	30-N	0	X	177	0
20' TO 25' TREES					
Laurus n.	25-I	0	X	491	0
	25-P	6	X	246	1,476
	25-N	0	X	123	0
15' TO 20' TREES					
	20-I	0	X	314	0
	20-P	0	X	157	0
	20-N	0	X	79	0
10' TO 15' TREES					
Acre r., Olea e., Magnolia g. Little	15-I	1	X	177	177
Gem, Lagerstroemia i.	15-P	15	X	88	1,320
	15-N	0	X	44	0
TOTAL					64,731

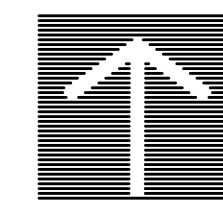



C CONCEPTUAL OUTDOOR PATIO SPACE
SCALE: NTS

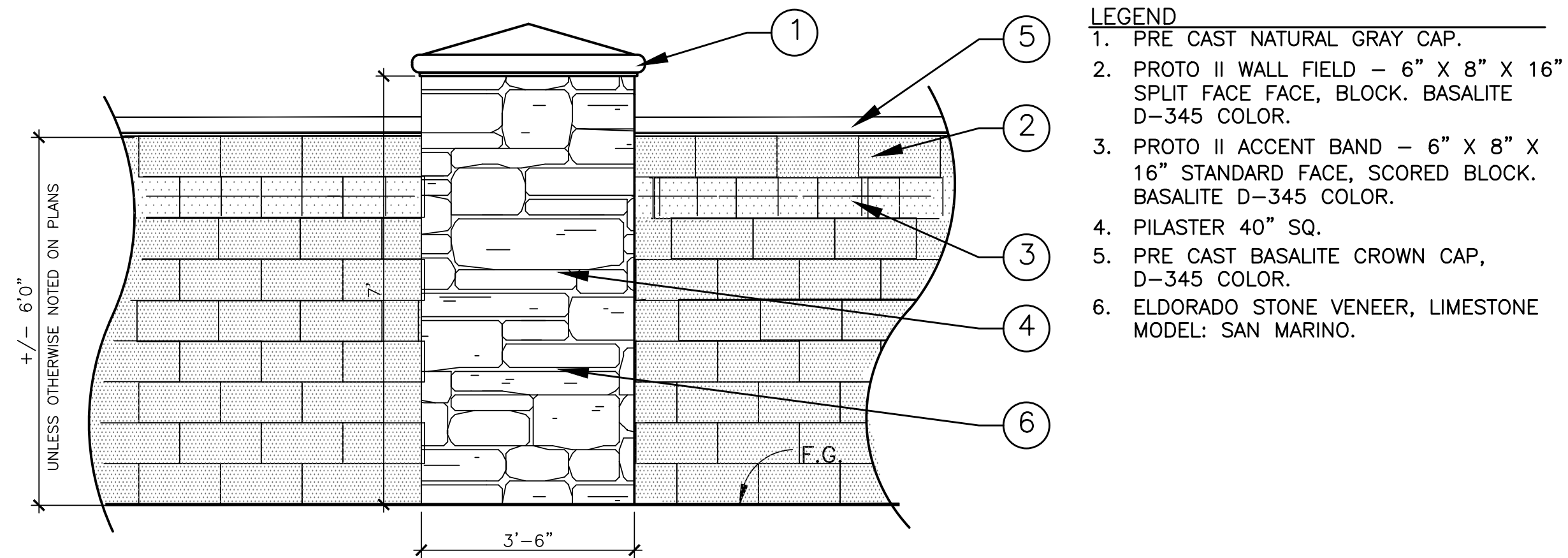

A MASONRY WALL - ELEVATION
SCALE: 1/2" = 1'-0"

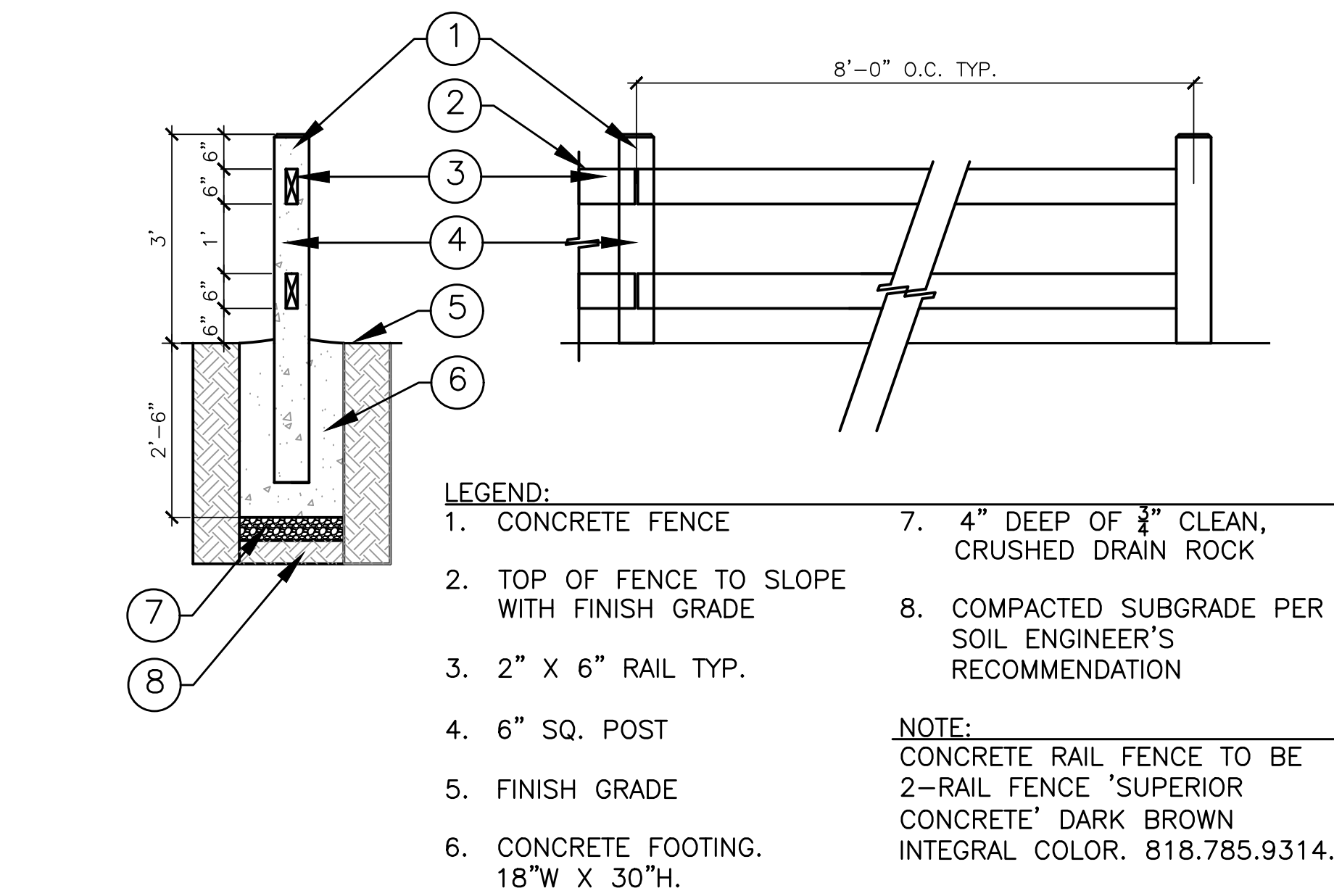
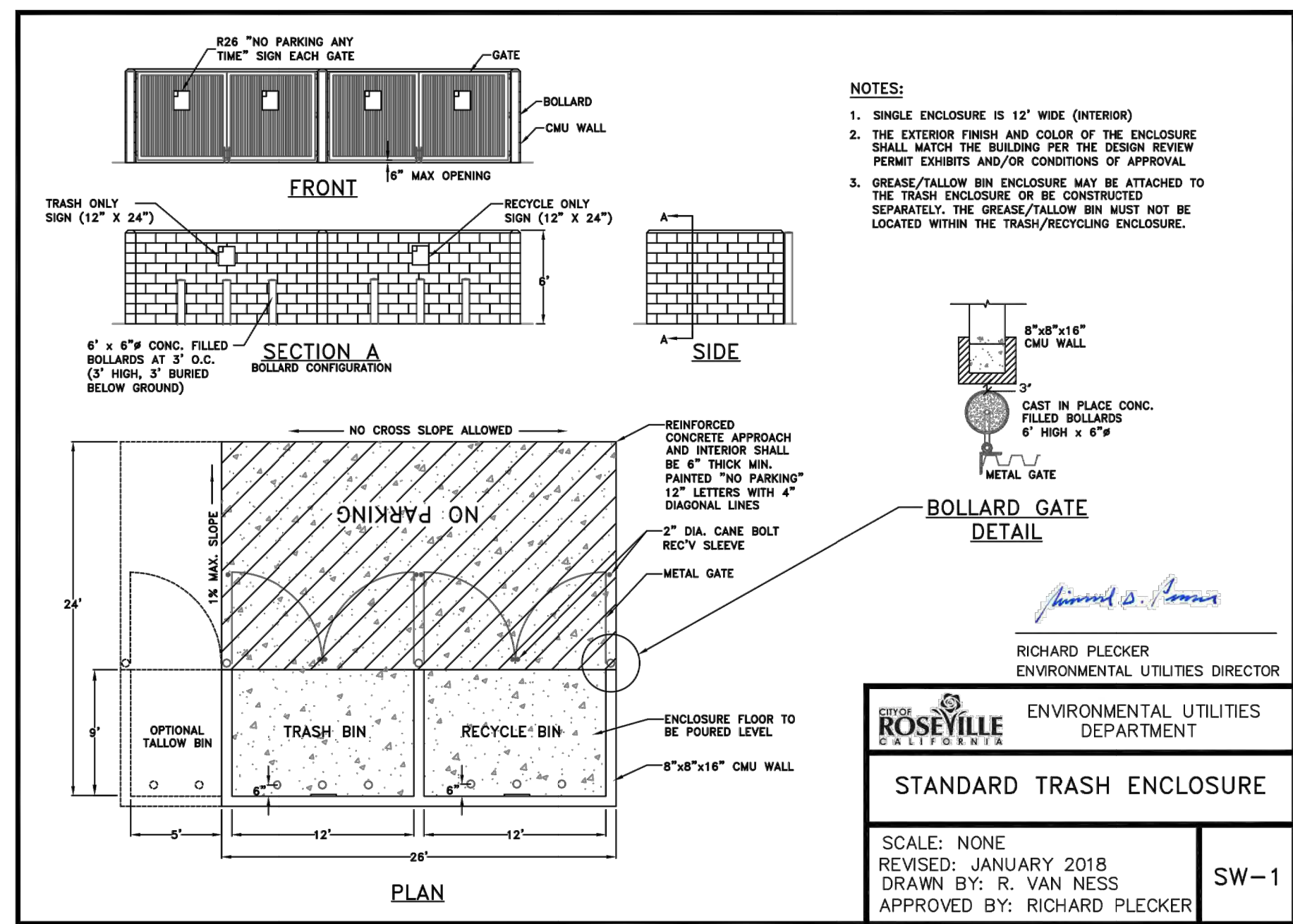

B CONCRETE RAIL FENCE
SCALE: 1/2" = 1' - 0"